

6227-SC Light Duty Single Footswitch



Technology Ltd

Cost effective range - ex stock delivery

- Low profile, rear hinged switch designed for improved user comfort
- All plastic construction with raised tread pattern and anti-slip pad
- Innovative design make it an ideal product for OEM use



Reference Dimensions

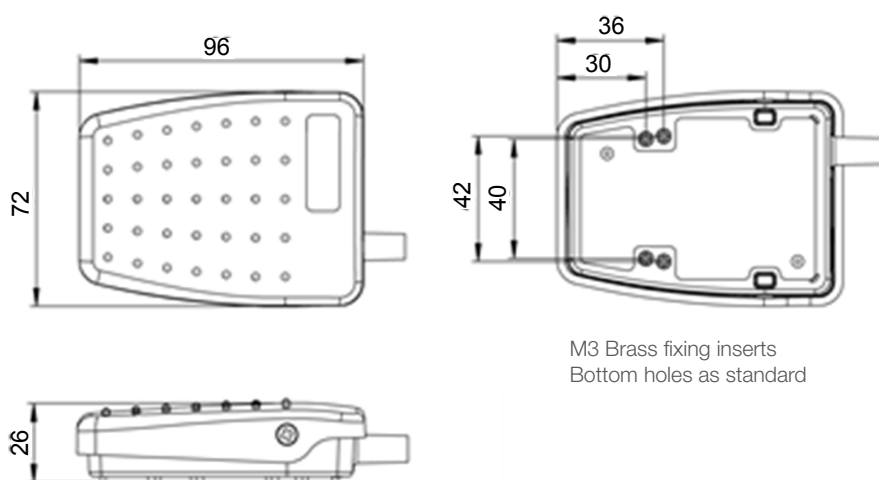

M3 Brass fixing inserts
Bottom holes as standard

General specifications

Standards/ approvals	Footswitch: low voltage directive 2017/35/EU, EN 60950
Degree of protection	EN 60529 IPX2
Connection method	2 m of black cable with stripped ends
Electrical rating	6A 250V AC

Contact configuration	SPST N/O ((Single pole normally open), Momentary action
Operating temperature range	-20°C to + 80° C
Body material	Thermoplastic
Weigh	0.12 kg
Additional Information	Black cover, black base

Minimum delivered batch quantities - 100 pcs

Accessories

Part Number	Description
6202-0001	Single black, RAL 9005 guard
6202-0002	Single gray, RAL 7035 guard
6202-0003	Twin Grey, RAL 7035 guard



With 6202 Guard

